

Portable Pilates Studio WORKOUT GUIDE

DX-1041N

empower.

See reverse for assembly instructions, guidelines and warnings prior to exercising

"V" CURL

- Lie on back with straps crossed and feet in straps. Hold bar above forehead with arms straight
- Extend legs vertically up to sky. Separate legs in a "V" shape. This is your starting position
- Contract abs and slowly lower legs to floor, bringing bar forward
- As you lower legs, lift upper body off floor, coming to a seated "V" position
- "V" curl should be slow and controlled, never fast



LOWER, MIDDLE ABS

SIDE-LYING LEG LIFT

- Lie on left side with top leg straight and bottom leg bent
- Place both straps on right foot
- Push bar out over head to help support body
- Slowly raise right leg up to sky, stop when you feel a stretch, then slowly lower leg back toward ground
- Complete a full set with right leg, then switch sides for a complete set on left leg



INNER/OUTER THIGHS

BRIDGE

- Lie on back, knees bent to a 90 degree angle and feet flat on floor
- Place feet in straps and hold bar at waist level
- Lift hips and pelvis up to sky as you extend bar overhead
- Keep abs, low back, and lower body tight
- Slowly lower hips and bring bar back to waist



ABS/BUTT/HAMSTRINGS

HERO TOE TAP

- Lie on back with feet in straps. Hold bar above head with arms straight
- Extend legs vertically up to sky. This is your starting position
- Keeping abs tight, slowly lower right leg toward floor
- Tighten and use muscles in leg to lower as far as possible. At first you may not be able to touch ground
- Slowly raise right leg back up to starting position
- Repeat for left leg



HAMSTRINGS/BUTT/QUADS

DOUBLE LEG PULL

- Lie on back with feet in straps. Hold bar above head with arms straight
- Extend legs vertically up to sky. This is your starting position
- Squeeze abs and glutes as you lift hips and feet up to sky
- At the same time, pull bar overhead for resistance
- Slowly lower hips to floor



ABS/BUTT

ROLL-UP

- Lie on back with legs extended vertically and feet in straps
- Hold bar overhead with arms extended
- Contract abs and slowly roll body forward, bringing legs to floor, coming to a seated position
- Allow upper body and bar to stretch toward feet, then slowly roll back to starting position, bringing bar back overhead
- Roll-up should be slow and controlled, never fast



ABS/ENTIRE CORE

PORTABLE PILATES STUDIO ASSEMBLY INSTRUCTIONS

Your Portable Pilates Studio consists of 2 easily assembled halves. Half "A" has 2 BUTTON HOLES and half "B" has 2 INSERT BUTTONS (as shown in Figure 1 and Detail 1 below).

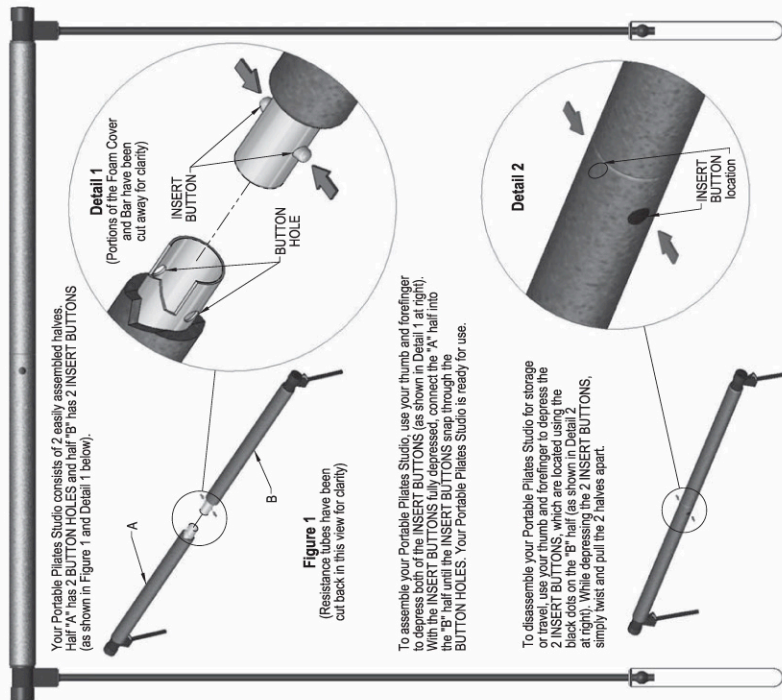

Figure 1

(Resistance tubes have been cut back in this view for clarity)

To assemble your Portable Pilates Studio, use your thumb and forefinger to depress both of the INSERT BUTTONS (as shown in Detail 1 at right). With the INSERT BUTTONS fully depressed, connect the "A" half into the "B" half until the INSERT BUTTONS snap through the BUTTON HOLES. Your Portable Pilates Studio is ready for use.

To disassemble your Portable Pilates Studio for storage or travel, use your thumb and forefinger to depress the 2 INSERT BUTTONS, which are located using the "A" half into the "B" half (as shown in Detail 2 at right). While the 2 INSERT BUTTONS are depressed, simply twist and pull the 2 halves apart.

empower.

INTRODUCTION TO PILATES

Pilates utilizes the body's middle muscles to stabilize, align, and strengthen postural alignment. It focuses on the core postural muscles which maintain the body's balance and provide support for the spine. In particular, Pilates exercises teach awareness of breath and alignment of the spine, and strengthen the deep torso muscles. Pilates works several muscle groups simultaneously through smooth, continuous motion, with a particular concentration on strengthening and stabilizing the core (the abdomen, back and pelvic region, sometimes referred to as the "powerhouse").

The focus in Pilates is on quality of movement rather than quantity. One feels invigorated rather than exhausted after a session. Pilates is a balanced approach that overworks no muscle group, allowing the body to move as an efficient, holistic system in sport and daily activity.

Pilates-style exercise will give you:

- A controlled, total body workout—low intensity, non-impact, gentle to the heart and joints
- Relief from some forms of back, neck, shoulder and knee pain, chronic weaknesses and muscle imbalances
- Flexibility
- A tapered waistline and lifted derrière
- An invigorated, energized feeling, not fatigue

TENSIONING THE PORTABLE PILATES STUDIO RESISTANCE TUBES

If you need to, you may increase the tension of the resistance tubes. To achieve this, refer to the following photos that illustrate the correct procedure:



1. Either standing or lying on your back, hold the bar with hands inside the resistance tubes, near the straps.



2. Move hands to the ends of bar and, with thumbs holding tubes to bar, pull the bar with hands inside the resistance tubes, near the straps, wearing tubes around bar.



3. Return hands to the starting position.



4. Rotate bar again, tensioning tubes to desired resistance, and proceed with your workout.

WARNINGS & GUIDELINES

Carefully read and follow these important warnings and guidelines prior to exercising. These warnings, combined with a common sense approach to a fitness program designed in conjunction with your doctor, should reduce the likelihood of injury and increase your chances of success. Before using this product, please consult your personal physician for a complete physical examination. Frequent and strenuous exercise should be approved by your doctor. If any discomfort should result from your use of this product, stop exercising and consult your doctor. Proper use of this product is essential. Please keep all children away from the equipment during use and when equipment is unattended. Always wear appropriate clothing, including athletic shoes when exercising. Do not wear loose clothing that could become caught during exercise. Periodic maintenance is required on all exercise equipment in order to keep it in good condition. Inspect any tubes, balls, etc. for cuts, tears or abrasions prior to each use. Maintain proper form and perform all exercises in a slow, controlled manner. Elbows, knees and shoulders should be unlocked and relaxed. Injury may result if proper form is not used for each exercise. Consult a certified personal trainer if unsure of how to perform any exercise. You should gradually increase the difficulty of your fitness routine, especially if you were not following a fitness regime prior to using this equipment. If you find that you are unable to complete a set of repetitions without feeling overly fatigued or without maintaining proper form, reduce the difficulty of your regimen.